

REMOTE CONTROL SYSTEM

RCV-125

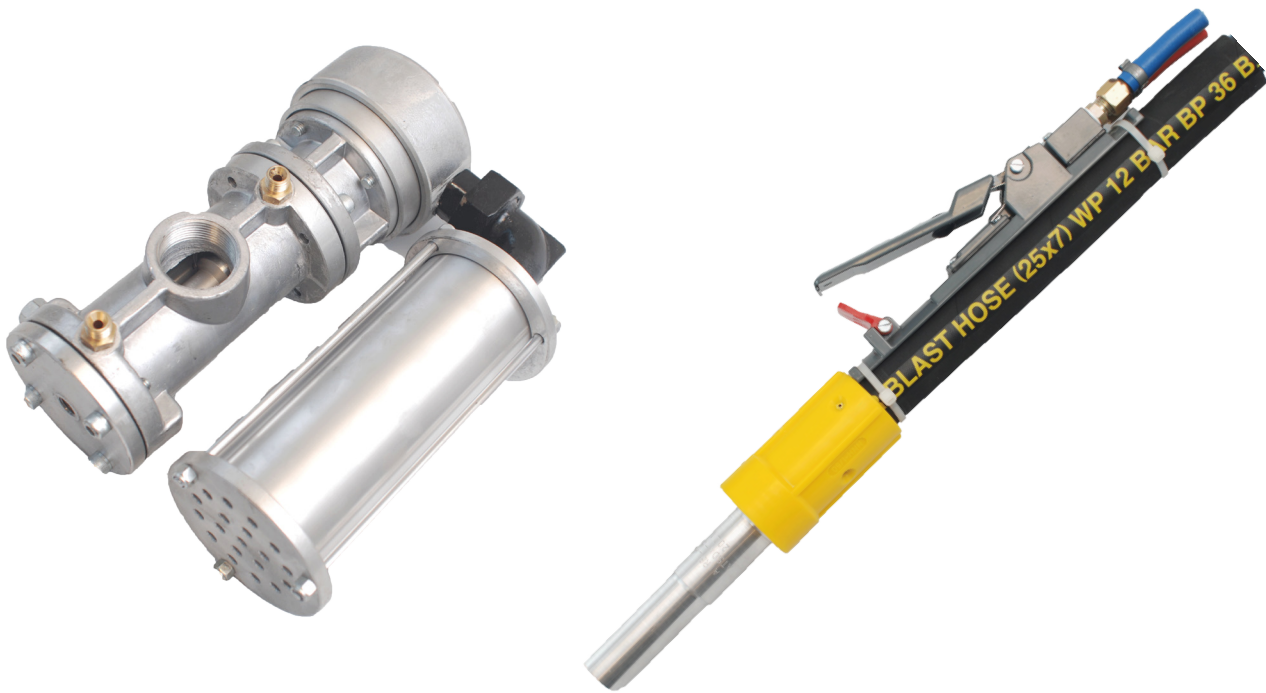

AIRBLAST



The RCV-125 pressure-release pneumatic systems operate on the return-air principle. A handle installed at the nozzle connects pneumatically to inlet and outlet valves on the blast machine. With the safety petcock on the inlet valve closed, the operator depresses the handle which opens the inlet valve and closes the outlet to start blasting; releasing the handle reverses the process and blasting stops. This safety system stops blasting should the operator lose control of the nozzle. And when the blast session is over, the safety petcock is opened to prevent activation, even when the handle is depressed.

For applications that require frequent starts and stops, machines should be equipped with pressure-hold pneumatic remote controls, which keep the blast machine under pressure but allow the operator to start and stop blasting as frequently as needed. The machine is pressurized and depressurized manually, and the remote control handle controls the on/off of the abrasive and air independently. These systems are available in pneumatic and electric models.

Airblast offers a full selection of remote control systems. Contact Airblast to discuss which system is most suitable for your specific application.

RCV-125 REMOTE CONTROL VALVES & DMH-125 DEADMAN HANDLE

Part no.	Description
1200000	RCV-125/20 1¼" REMOTE CONTROL VALVE COMPLETE INCLUDING: Silencer/Muffler, 20 meters twin hose coupled, DMH-125 Deadman Handle
1201000	RCV-125/40 1¼" REMOTE CONTROL VALVE COMPLETE INCLUDING: Silencer/Muffler, 40 meters twin hose coupled, DMH-125 Deadman Handle
1202000	RCV-125/B REMOTE CONTROL VALVE ONLY (SILENCER INCLUDED)
1203000	DMH-125 Deadman Handle for twin line remote control operation

RCV-125 REMOTE CONTROL VALVE - Parts

Item	Part no.	Description	Qty
01	1206000	Valve housing	1
02	1206100	Bleed-off cylinder housing	1
03	1206200	Bleed-off manifold	1
04	1206300	Top cover	1
05	1206400	Inlet valve	1
06	1206500	Bleed-off cylinder	1
07	1206600	Piston	2
08	1206700	Bottom plate	1
09	1206800	Diaphragm	* 1
10	1206900	Piston seal	* 2
11	1207000	O-ring	* 3
12	1207100	Packing	* 2
13	1178000	Brass hex nipple ¼"	1
14	1178000	Brass hex nipple ¼"	1
15	1152000	Ball valve ¼"	2
16	1207200	Piston screw 8x15	2
17	2225400	Hex nipple ¾"	1
18	1207400	Screw 8x25	12
19	1207600	Silencer housing	1
20	1207700	Silencer top cover	1
21	1207800	Silencer bottom plate	1
22	1207900	Silencer housing pin 5x215	3
23	1208000	Silencer cartridge	1
24	1208100	Silencer cartridge support	1
25	1208600	Nut	6
26	1208400	Union elbow	1
27	2225400	Hex nipple ¾"	1
28	1208700	Check valve (not shown)	1
29	1207500	Plug ¼" (not shown)	1
30	1209600	O-ring	*

All *-marked items are included in RCV-125 Repair kit (art.nr. 12050) in quantities shown.

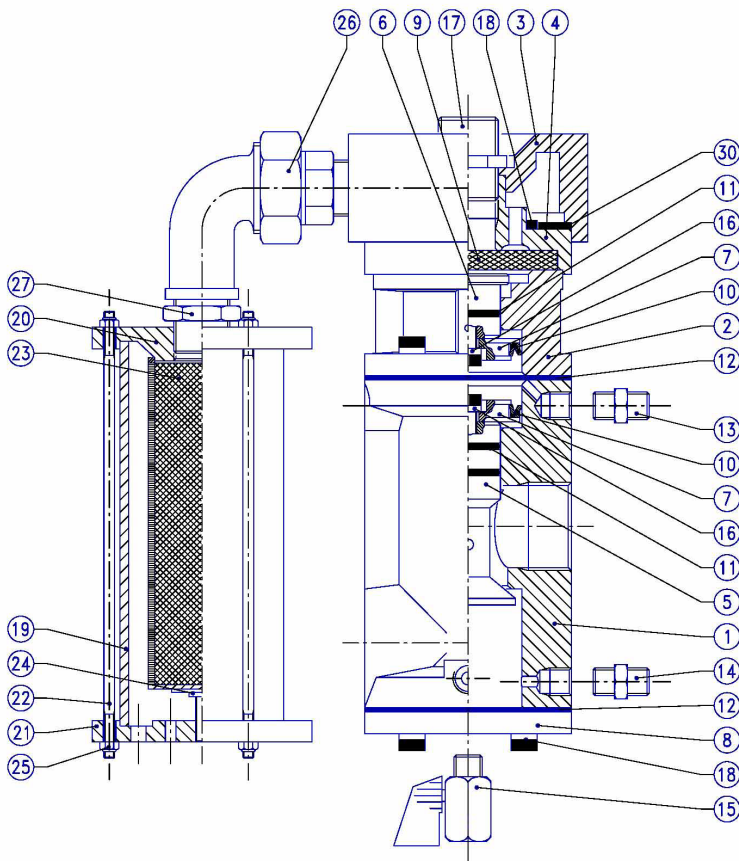

TWIN LINE HOSE ASSEMBLIES

1144300	Twin hose coupled, length of 5 mtrs.
1144400	Twin hose coupled, length of 20 mtrs.
1144500	Twin hose coupled, length of 40 mtrs.

DMH-125 DEADMAN HANDLE - Parts

Item	Part no.	Description	Qty
01	1203100	Handle body	1
02	1203200	Lever	1
03	1203300	Pneumatic manifold	1
04	1203400	Lever safety lock	1
05	1203500	Gasket	1
06	1203600	Rubber insert	1
07	1203700	Reduction nipple ¼" x ⅛" (restricted)	1
08	1203800	Reduction nipple ¼" x ⅛"	1
09	1203900	Spring	2
10	1204000	Screw 5x40	2
11	1204100	Screw 4x25	2
12	1204200	Screw 4x10	4
13	1204300	Lock nut	2

